



南京航空航天大学
Nanjing University of Aeronautics and Astronautics

ICCV2021

Swin Transformer: Hierarchical Vision Transformer using Shifted Windows

I. Introduction

II. model

III. Shifted Window based Self-Attention

IV. Experiments

V. Conclusion

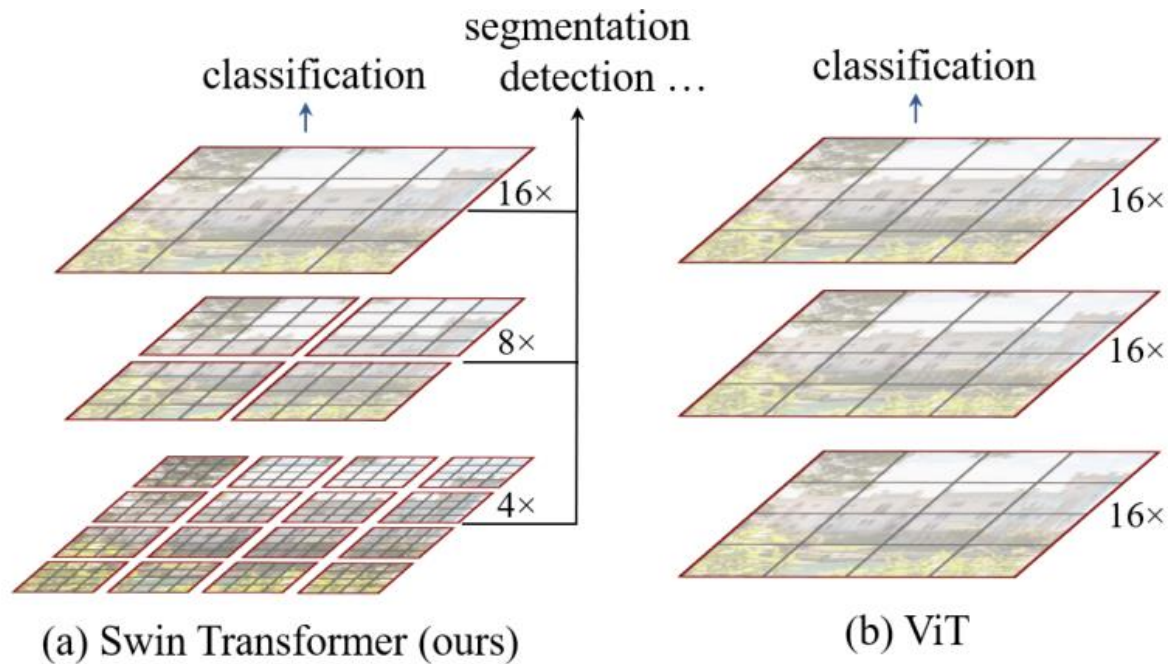

Figure 1. (a) The proposed Swin Transformer builds hierarchical feature maps by merging image patches (shown in gray) in deeper layers and has linear computation complexity to input image size due to computation of self-attention only within each local window (shown in red). It can thus serve as a general-purpose backbone for both image classification and dense recognition tasks. (b) In contrast, previous vision Transformers [20] produce feature maps of a single low resolution and have quadratic computation complexity to input image size due to computation of self-attention globally.

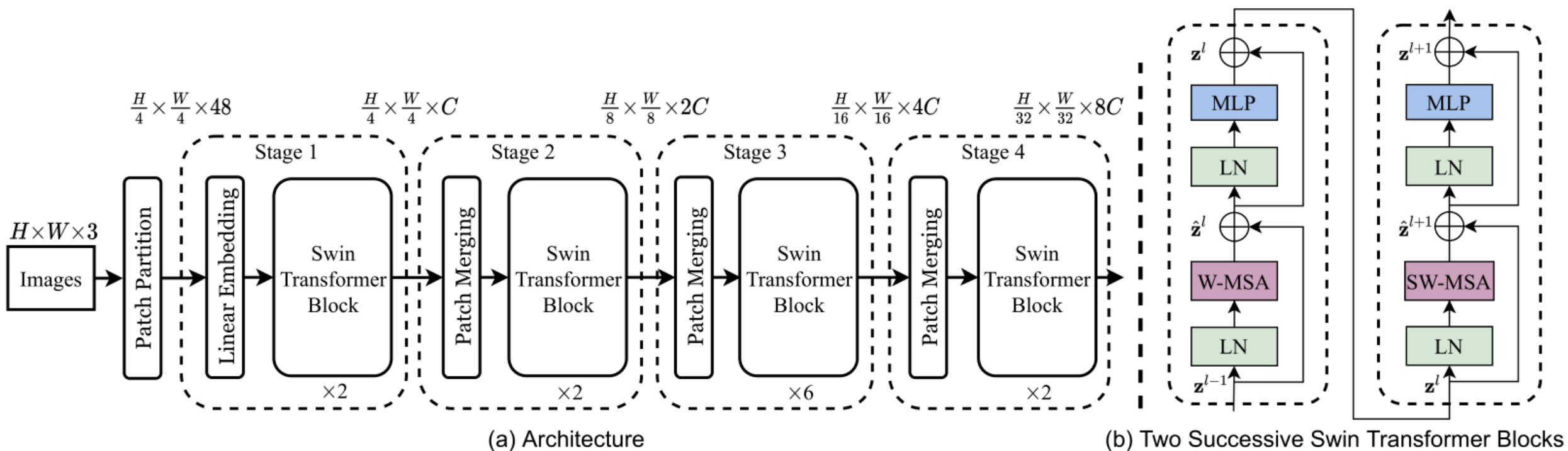

Figure 3. (a) The architecture of a Swin Transformer (Swin-T); (b) two successive Swin Transformer Blocks (notation presented with Eq. (3)). W-MSA and SW-MSA are multi-head self attention modules with regular and shifted windowing configurations, respectively.



patch merging

$H \times W \times C$

1	2	1	2
3	4	3	4
1	2	1	2
3	4	3	4

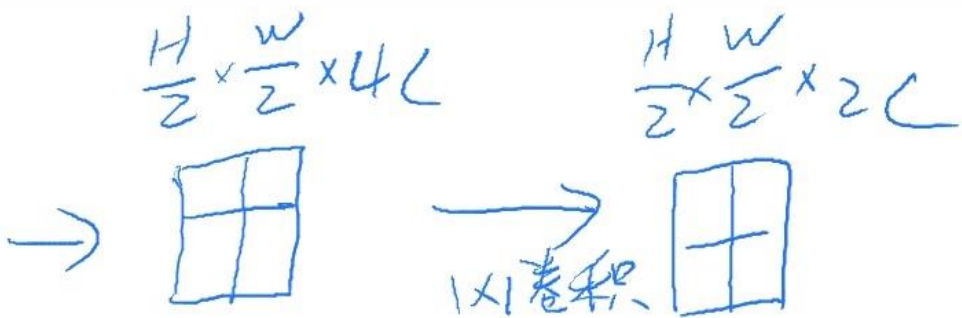
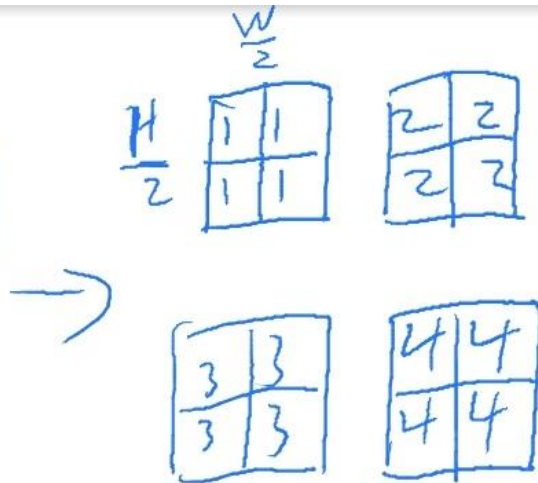

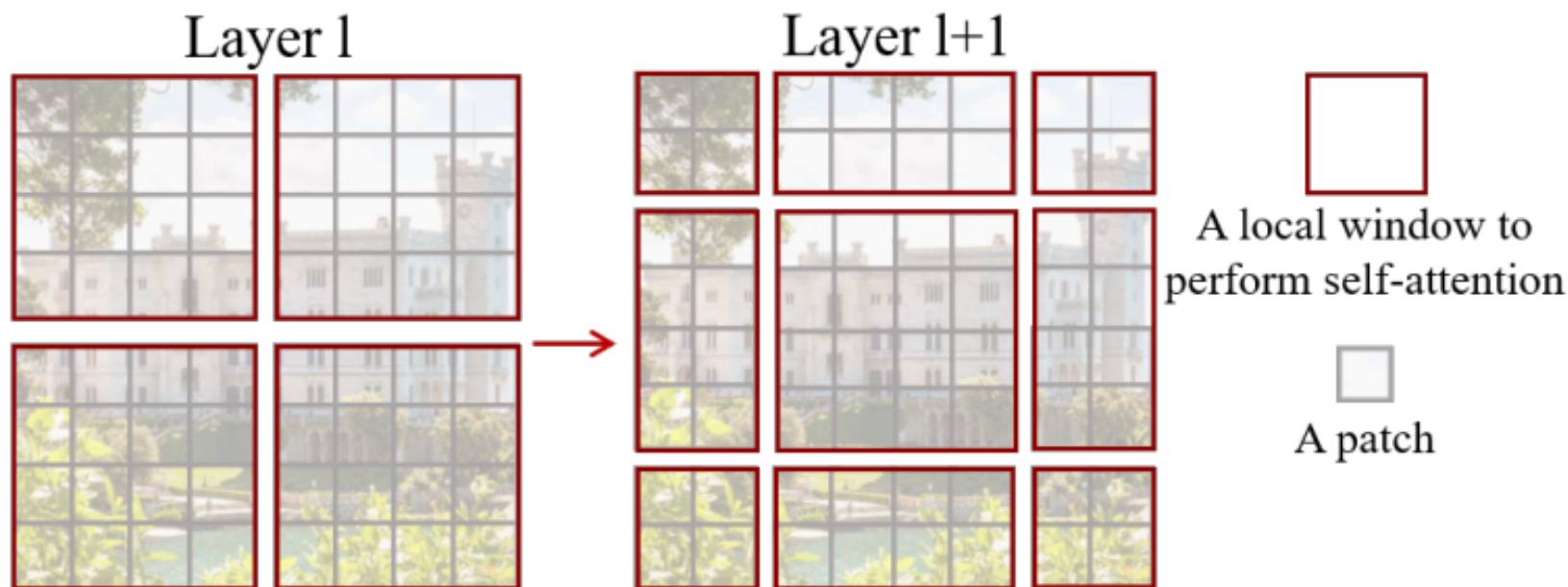
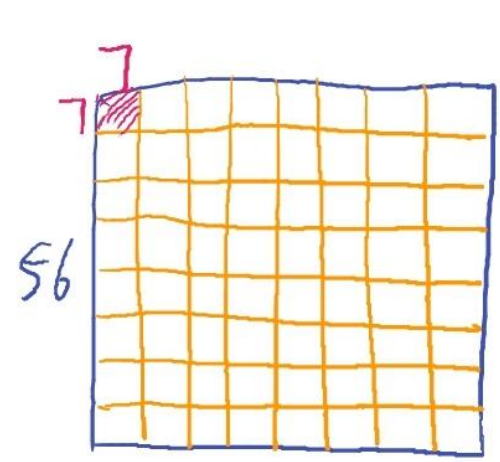

Figure 2. An illustration of the *shifted window* approach for computing self-attention in the proposed Swin Transformer architecture. In layer l (left), a regular window partitioning scheme is adopted, and self-attention is computed within each window. In the next layer $l + 1$ (right), the window partitioning is shifted, resulting in new windows. The self-attention computation in the new windows crosses the boundaries of the previous windows in layer l , providing connections among them.

Shifted Window based Self-Attention

$$\Omega(\text{MSA}) = 4hwC^2 + 2(hw)^2C, \quad (1)$$

$$\Omega(\text{W-MSA}) = 4hwC^2 + 2M^2hwC, \quad (2)$$



56x56x96

an image of $h \times w$ patches
 C 是特征的维度
 m 是一个窗口中一条边有几个 patch

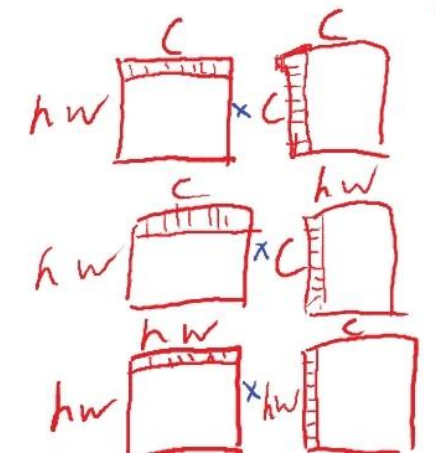
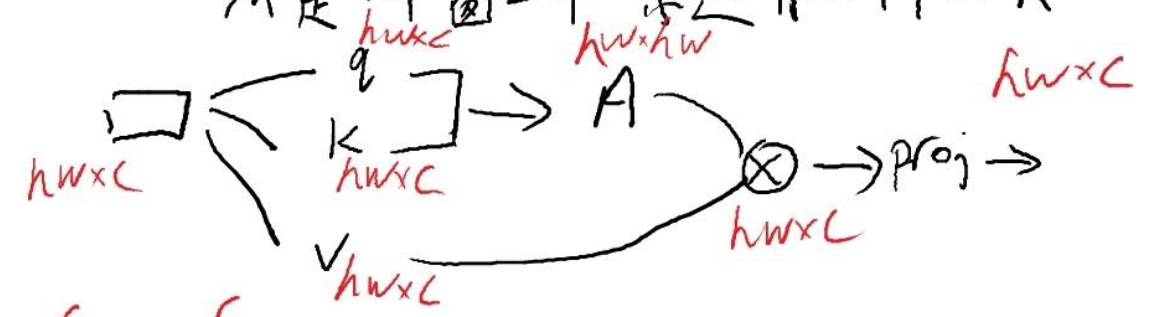

$hw c^2$
 $(hw)^2 c$
 $(hw)^2 c$

$$\begin{aligned} \Omega(\text{MSA}) &= 3hwc^2 + (hw)^2c + (hw)^2c + hwc^2 \\ &= 4hwc^2 + 2(hw)^2c \quad (1) \end{aligned}$$

$$\begin{aligned} \Omega(\text{W-MSA}) &= \frac{h}{m} \times \frac{w}{m} \times (4m^2c^2 + 2m^4c) \\ &= 4hwc^2 + 2m^2hwC \quad (2) \end{aligned}$$

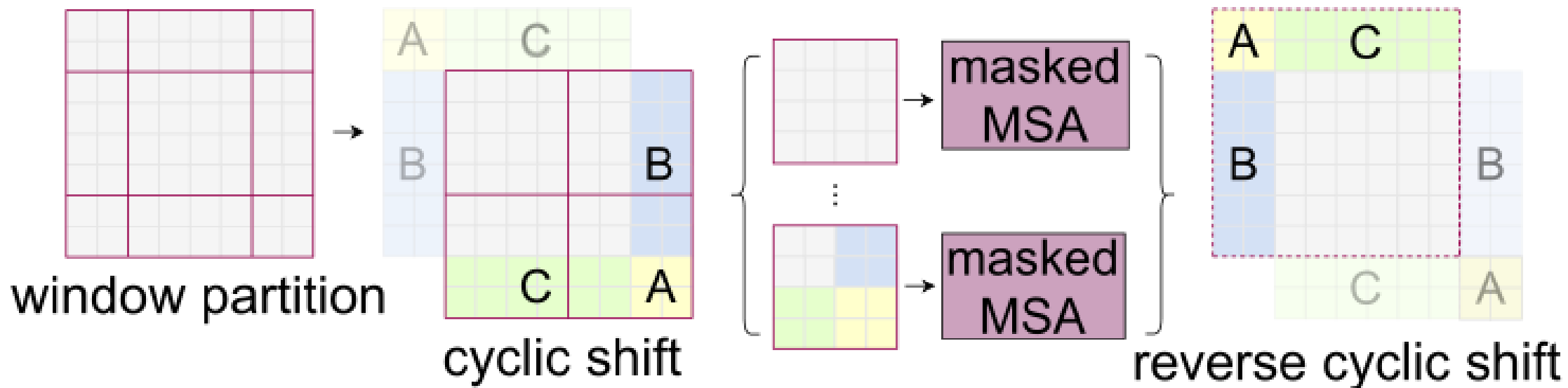

Figure 4. Illustration of an efficient batch computation approach for self-attention in shifted window partitioning.

Shifted Window based Self-Attention

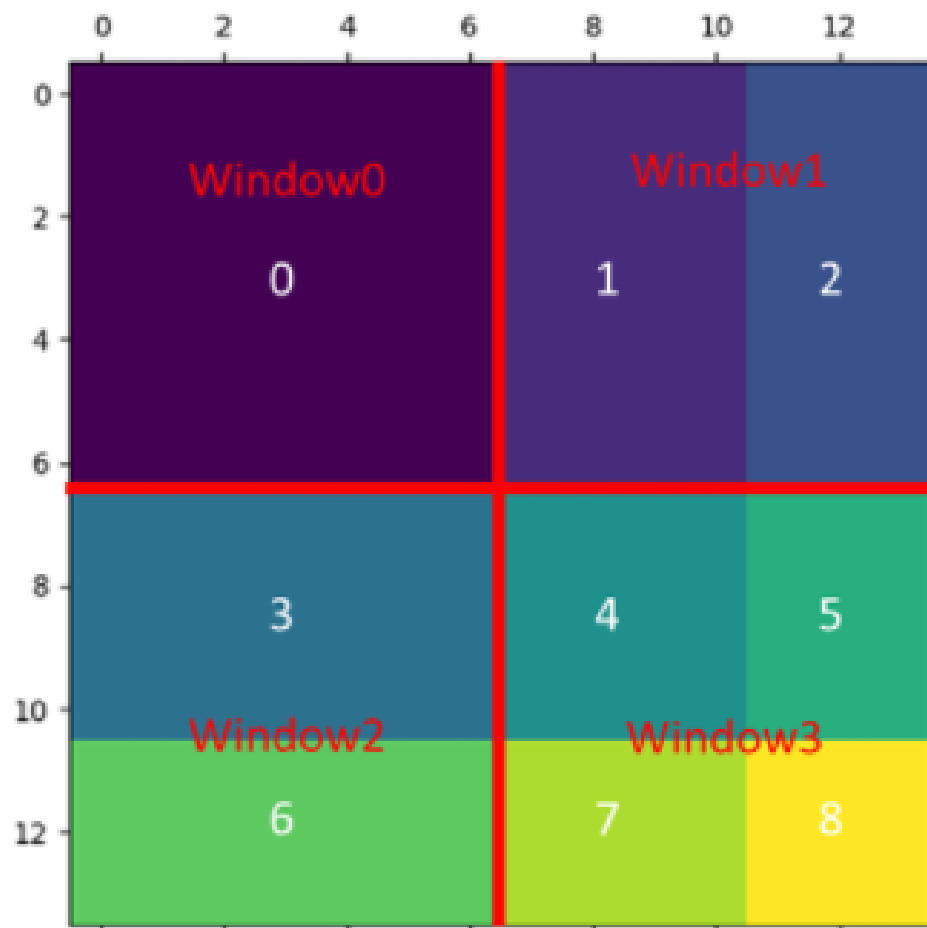
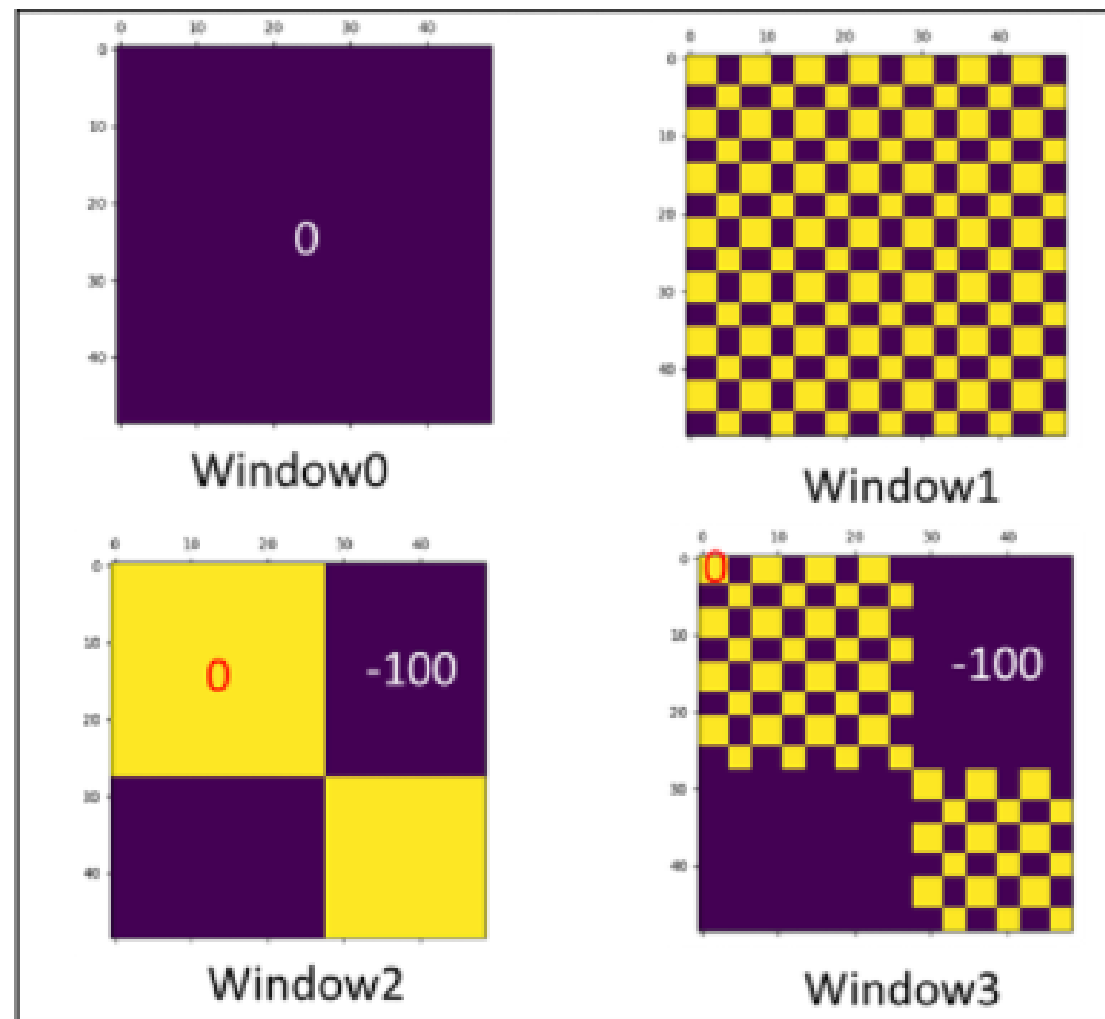

Image Mask
(14x14, window 7x7, shift 3)



Attn Mask

image classification

(a) Regular ImageNet-1K trained models

method	image size	#param.	FLOPs	throughput (image / s)	ImageNet top-1 acc.
RegNetY-4G [48]	224 ²	21M	4.0G	1156.7	80.0
RegNetY-8G [48]	224 ²	39M	8.0G	591.6	81.7
RegNetY-16G [48]	224 ²	84M	16.0G	334.7	82.9
EffNet-B3 [58]	300 ²	12M	1.8G	732.1	81.6
EffNet-B4 [58]	380 ²	19M	4.2G	349.4	82.9
EffNet-B5 [58]	456 ²	30M	9.9G	169.1	83.6
EffNet-B6 [58]	528 ²	43M	19.0G	96.9	84.0
EffNet-B7 [58]	600 ²	66M	37.0G	55.1	84.3
ViT-B/16 [20]	384 ²	86M	55.4G	85.9	77.9
ViT-L/16 [20]	384 ²	307M	190.7G	27.3	76.5
DeiT-S [63]	224 ²	22M	4.6G	940.4	79.8
DeiT-B [63]	224 ²	86M	17.5G	292.3	81.8
DeiT-B [63]	384 ²	86M	55.4G	85.9	83.1
Swin-T	224 ²	29M	4.5G	755.2	81.3
Swin-S	224 ²	50M	8.7G	436.9	83.0
Swin-B	224 ²	88M	15.4G	278.1	83.5
Swin-B	384 ²	88M	47.0G	84.7	84.5

(b) ImageNet-22K pre-trained models

method	image size	#param.	FLOPs	throughput (image / s)	ImageNet top-1 acc.
R-101x3 [38]	384 ²	388M	204.6G	-	84.4
R-152x4 [38]	480 ²	937M	840.5G	-	85.4
ViT-B/16 [20]	384 ²	86M	55.4G	85.9	84.0
ViT-L/16 [20]	384 ²	307M	190.7G	27.3	85.2
Swin-B	224 ²	88M	15.4G	278.1	85.2
Swin-B	384 ²	88M	47.0G	84.7	86.4
Swin-L	384 ²	197M	103.9G	42.1	87.3

Table 1. Comparison of different backbones on ImageNet-1K classification. Throughput is measured using the GitHub repository of [68] and a V100 GPU, following [63].

object detection and instance segmentation

(a) Various frameworks

Method	Backbone	AP ^{box}	AP ₅₀ ^{box}	AP ₇₅ ^{box}	#param.	FLOPs	FPS
Cascade	R-50	46.3	64.3	50.5	82M	739G	18.0
Mask R-CNN	Swin-T	50.5	69.3	54.9	86M	745G	15.3
ATSS	R-50	43.5	61.9	47.0	32M	205G	28.3
	Swin-T	47.2	66.5	51.3	36M	215G	22.3
RepPointsV2	R-50	46.5	64.6	50.3	42M	274G	13.6
	Swin-T	50.0	68.5	54.2	45M	283G	12.0
Sparse R-CNN	R-50	44.5	63.4	48.2	106M	166G	21.0
	Swin-T	47.9	67.3	52.3	110M	172G	18.4

(b) Various backbones w. Cascade Mask R-CNN

	AP ^{box}	AP ₅₀ ^{box}	AP ₇₅ ^{box}	AP ^{mask}	AP ₅₀ ^{mask}	AP ₇₅ ^{mask}	#param	FLOPs	FPS
DeiT-S [†]	48.0	67.2	51.7	41.4	64.2	44.3	80M	889G	10.4
R50	46.3	64.3	50.5	40.1	61.7	43.4	82M	739G	18.0
Swin-T	50.5	69.3	54.9	43.7	66.6	47.1	86M	745G	15.3
X101-32	48.1	66.5	52.4	41.6	63.9	45.2	101M	819G	12.8
Swin-S	51.8	70.4	56.3	44.7	67.9	48.5	107M	838G	12.0
X101-64	48.3	66.4	52.3	41.7	64.0	45.1	140M	972G	10.4
Swin-B	51.9	70.9	56.5	45.0	68.4	48.7	145M	982G	11.6

(c) System-level Comparison

Method	mini-val		test-dev		#param.	FLOPs
	AP ^{box}	AP ^{mask}	AP ^{box}	AP ^{mask}		
RepPointsV2* [12]	-	-	52.1	-	-	-
GCNet* [7]	51.8	44.7	52.3	45.4	-	1041G
RelationNet++* [13]	-	-	52.7	-	-	-
SpineNet-190 [21]	52.6	-	52.8	-	164M	1885G
ResNeSt-200* [78]	52.5	-	53.3	47.1	-	-
EfficientDet-D7 [59]	54.4	-	55.1	-	77M	410G
DetectoRS* [46]	-	-	55.7	48.5	-	-
YOLOv4 P7* [4]	-	-	55.8	-	-	-
Copy-paste [26]	55.9	47.2	56.0	47.4	185M	1440G
X101-64 (HTC++)	52.3	46.0	-	-	155M	1033G
Swin-B (HTC++)	56.4	49.1	-	-	160M	1043G
Swin-L (HTC++)	57.1	49.5	57.7	50.2	284M	1470G
Swin-L (HTC++)*	58.0	50.4	58.7	51.1	284M	-

Table 2. Results on COCO object detection and instance segmentation. [†]denotes that additional decovolution layers are used to produce hierarchical feature maps. * indicates multi-scale testing.

semantic segmentation

ADE20K		val	test	#param.	FLOPs	FPS
Method	Backbone	mIoU	score			
DANet [23]	ResNet-101	45.2	-	69M	1119G	15.2
DLab.v3+ [11]	ResNet-101	44.1	-	63M	1021G	16.0
ACNet [24]	ResNet-101	45.9	38.5	-		
DNL [71]	ResNet-101	46.0	56.2	69M	1249G	14.8
OCRNet [73]	ResNet-101	45.3	56.0	56M	923G	19.3
UperNet [69]	ResNet-101	44.9	-	86M	1029G	20.1
OCRNet [73]	HRNet-w48	45.7	-	71M	664G	12.5
DLab.v3+ [11]	ResNeSt-101	46.9	55.1	66M	1051G	11.9
DLab.v3+ [11]	ResNeSt-200	48.4	-	88M	1381G	8.1
SETR [81]	T-Large [‡]	50.3	61.7	308M	-	-
UperNet	DeiT-S [†]	44.0	-	52M	1099G	16.2
UperNet	Swin-T	46.1	-	60M	945G	18.5
UperNet	Swin-S	49.3	-	81M	1038G	15.2
UperNet	Swin-B [‡]	51.6	-	121M	1841G	8.7
UperNet	Swin-L [‡]	53.5	62.8	234M	3230G	6.2

Table 3. Results of semantic segmentation on the ADE20K val and test set. [†] indicates additional deconvolution layers are used to produce hierarchical feature maps. [‡] indicates that the model is pre-trained on ImageNet-22K.

Ablation Study

	ImageNet		COCO		ADE20k
	top-1	top-5	AP ^{box}	AP ^{mask}	mIoU
w/o shifting	80.2	95.1	47.7	41.5	43.3
shifted windows	81.3	95.6	50.5	43.7	46.1
no pos.	80.1	94.9	49.2	42.6	43.8
abs. pos.	80.5	95.2	49.0	42.4	43.2
abs.+rel. pos.	81.3	95.6	50.2	43.4	44.0
rel. pos. w/o app.	79.3	94.7	48.2	41.9	44.1
rel. pos.	81.3	95.6	50.5	43.7	46.1

Table 4. Ablation study on the *shifted windows* approach and different position embedding methods on three benchmarks, using the Swin-T architecture. w/o shifting: all self-attention modules adopt regular window partitioning, without *shifting*; abs. pos.: absolute position embedding term of ViT; rel. pos.: the default settings with an additional relative position bias term (see Eq. (4)); app.: the first scaled dot-product term in Eq. (4).

1. The **shifted windowing scheme** brings greater efficiency by limiting self-attention computation to non-overlapping local windows while also allowing for cross-window connection.
2. This **hierarchical architecture** has the flexibility to model at various scales and has linear computational complexity with respect to image size.
3. Swin Transformer, that capably serves as a **general-purpose backbone** for computer vision, and it performs extremely well in almost all visual fields.



南京航空航天大学

Nanjing University of Aeronautics and Astronautics

Thanks for Listening

